

# Hydraulic NovoDock L320/L330i

## Adjusting instruction

**Article No. Hydraulic unit:** DS0110200  
**Motor power:** 0,75kW  
**Design:** Hinged lip hydraulic unit  
with 2 solenoid valves



### 1 Basic

This adjusting instruction is addressed to those which are involved in installation, maintenance and service work on hydraulic systems of dock levellers. All work on the hydraulic system must be carried out by experts/qualified persons. The relevant standards and regulations are assumed to be known.

With help of this adjusting instruction, an expert/qualified person can carry out all necessary adjustment work to the hydraulics. In addition, the instruction is intended to prevent not excluded hazards to life and health of the expert/qualified person or third parties. Any person who has been working on the hydraulic system must have read and understood this instruction manual from beginning to end.

Only manufacturer-approved hydraulic oils and spare parts are used. Otherwise there is no guarantee a proper function. In addition, the guarantee is void!

#### 1.1 Possible risks warning

Based on the risk analysis, the attention is drawn to the following possible risks:

**NOTE:** Observe that all installation, maintenance and repair work on the hydraulic unit is subject to generally accepted, statutory and other binding regulations on accident prevention and environmental protection, national regulations and recognized technical rules for the safe and correct execution of the work.

**ATTENTION:** The hydraulic unit contains electrical components. All electrical connection has to take place of a qualified electrician and after wiring plan.

**CAUTION:** Before starting work, ensure that the dock leveller is secured according to the specifications of the corresponding maintenance manuals to ensure safe working. If the hydraulic system is pressureless, the hydraulic unit must be disconnected from the power supply and the control must be protected against reconnection.

**ATTENTION:** The hydraulic unit and all related elements can be under pressure.

#### 1.2 Unit's location and mounting process

The hydraulic unit may only mount with the mounting bracket under the platform. Failure to comply may result in damage to the unit, especially to the plastic tank. See also the sketches of the installation situation in the appendix of this document.

Compliance with the principles of cleanliness is a basic prerequisite for trouble free operation of the hydraulic system. All hydraulic components are made with high accuracy. Any contamination will cause malfunction or shorten the lifetime.

When mounting the hydraulic unit must be used always clean tools. Never put components and connection accessories that are contaminated with hydraulic oil drop on painted surfaces. The most suitable cleaning aid is a crepe paper, because fibers from cleaning fabrics can cause malfunction.

The protective plugs of the hose connections must be removed only shortly before installation.

Check that all other components of the system are sufficiently clean. If this can't be ensured, the hoses and pipes must be cleaned with a suitable detergent and then blown with compressed air.

All screws must be properly tightened. Do not use parts with damaged or tight thread or do not apply excessive force when installing. Observe the tightening torques specified in the table 2 of this document.

### 1.3 Electrical installation and connecting to power supply

Connecting of all electrical components, the applicable regulations and standards must be complied with.

Before the hydraulic unit is connected to the power supply, the values of the values on the labels must be checked according to the values for the power supply. These are in particular the operating voltage, frequency and the required power consumption.

Protection against dangerous contact voltage must comply with the applicable regulations. In case of repair or maintenance on the electrical components, all applicable safety regulations must be observed.

### 1.4 Filling the tank with working fluid

The tank must not be filled with the hydraulic oil without using the appropriate filling filter device with the filtration. The filter should be smaller than 20µm. The grade of the filling oil should be at least of the cleanliness class 21/18/15 according to ISO 4406.

Ensure cleanliness of all circuit including hoses and cylinders.

Prevent any escape of the working fluid during handling and maintenance. If leakage of the working fluid occurs it is necessary to prevent contamination of the surrounding environment, particularly water sources. Remove the spilled oil by suitable chemical means, or sprinkle with suitable bulk material. The contaminated material must be disposed of in ecologically acceptable manner.

#### **Maximum oil level "OIL LEVEL MAX":**

- Mark "MAX" on the Tank shows the maximum oil level, when the dock leveller is in the lowest position.

**ATTENTION:** An oil level above "MAX" may cause oil from the seal may leak on the tank lid when the dock leveller is in the lowest end position (the cylinders are fully retracted).

## Minimum oil level:

- Minimum oil level in upper position must not fall under mark "MIN".

## Optimum oil level in resting position:

- The optimum oil level is in the upper area up to a maximum of 2cm below the "MAX" mark when the leveler is in the rest position.
- Depending on the cylinder volume, the oil level can be minimized ( $\pm 1$ cm).

**NOTE:** The maximum oil quantity of the hydraulic system is approx. 7 liter. Depending of the cylinder volume, the amount of oil varies slightly.



(Sketch of lower final position)

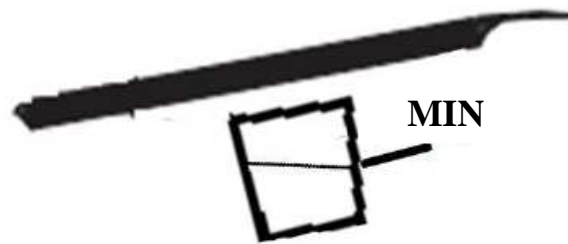

(Sketch of upper final position)

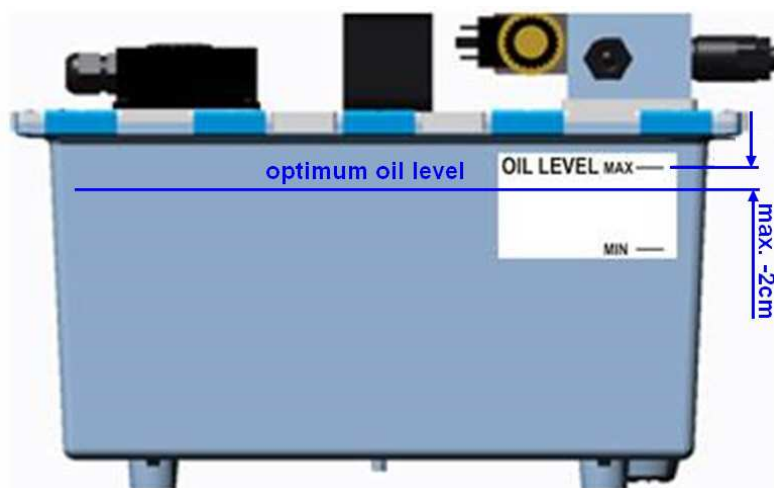

Optimum oil level in resting position (max. -2cm under "OIL LEVEL MAX")

## Table of recommended hydraulic oils:

Type	Name	Temp.-Area [° C]	Usage
Standard oil (DS0704440)	MD Performance hydraulic oil	- 20 to +50	Normal conditions
Low temperature oil (DS0702220)	AVIATICON HV-CHF	- 40 to +50	Unprotected and critical places (e.g. lower temperature and windy places)
Bio oil (DS0703300)	Plantolube	-20 to +50	Environmentally-friendly

The maximum oil temperature should not exceed the temperature range value specified in the table and should not exceed higher than 20°C above the ambient temperature.  
The hydraulic motor is not designed for the continuous operation. The load factor "S3" is not higher than allowed 20%.

## 2 Putting hydraulic unit into operation

Before the initial start-up of the equipment check that:

- The equipment is fully assembled and all appliances are correctly connected.
- The hydraulic tank is filled with specified oil according to the information under point 1.4.
- All connections are properly tightened and the hoses assembled without internal stress.
- The hydraulic and electrical connection corresponds with the diagram.
- The electric motor is correctly connected and that the indicated rotation is observed.

### 2.1 First Start

**ATTENTION:** The working pressure relief valve is factory set according to the diagram.

**NOTE:** After the circuit is filled the level of the working fluid in the tank is going to drop.

- Bring the electric motor into operation by pressing the "lift" button in short intervals (2s).
- Check the tightness of the hydraulic system, electric motor direction of turning and the noise level.
- Bleed the hydraulic system by at least 2-3 working-cycles of the dock leveller.
- Test all function of the leveller and the electric equipment.
- Check the hydraulic oil level. If necessary, add an appropriate amount of oil.

All hydraulic units were tested by the supplier before shipping. This means that the complete circuit of the unit is flushed.

If cannot be ensured that also other parts of hydraulic circuit are absolutely clean, a flushing procedure must be carried out.

- Make 10 working cycles of the dock leveller, drain the oil from the tank, clean the tank and filter, fill the tank with new oil as described in the chapter 1.4.

### 3 Adjusting of the hydraulic unit

#### Requirements:

- The electric and hydraulic components of the dock leveller are completely installed.
- A pressure gauge is connected to the measuring port "M", or direct in the hose line of the lift cylinders.

It is possible to use the "factory setting" for dock levellers in standard dimensions. The "factory settings" are definitely to check and depending on dimensions of the dock leveller to adjust new.

#### 3.1 Adjusting the lift pressure

The optimal pressure setting of the pressure relief valve "DB1" (see wiring diagram and identification on the hydraulic unit) is 15-20 bar above the necessary "floating pressure" for lifting.

**NOTE:** A too high pressure setting is not allowed and leads to an increased heating and hydraulic oil aging during operation. The oil change intervals can be significantly shortened, damage to the unit cannot be ruled out.

- Unlock valve "DV2" and turn clockwise to its stop (close).
- Press "Lift" button. If there is not enough pressure to lift the platform, unlock valve "DB1" and turn clockwise until the platform rises.
- Swing out the lip automatically.
- Lower platform with swing out hinged lip down to the lowest position.
- Valve "DB1" unscrew anticlockwise so far that the dock leveller no longer rises (lift pressure is too low).
- Press "Lift" button and keep it pressed. Turn valve "DB1" clockwise until the dock leveller begins to lift up (floats). Stop the screwing on valve, cross the dock leveller into the upper end position and the pressure measured= "floating pressure".
- Pressure setting by turning clockwise increased to the extent that in the upper end position of the platform, a pressure equal to "floating pressure plus 15-20 bar" is measured (about 1/4 turn).
- Secure valve "DB1" by tightening the lock nut and protect by screw protection lacquer to prevent unauthorized setting.
- Finally, check the tightness of the valves. Raise the leveller platform to the upper end position and turn the main switch to "OFF". If the platform does not sink, all valves are tight.

#### 3.2 Adjusting the swing in and out speed of the lip

The swing in and out movement of the lip is adjusted according to manufacturer specifications and can be adjusted as needed.

- Press "Lift" button.
- Open valve "DV2" by turning anticlockwise and adjust so that the lip swings back within approximately 2s.
- Secure adjustment by tightening the lock nut.

The swing out speed of the lip is not adjustable.

### 3.3 Adjusting the lowering speed of the platform

The lowering speed of the platform is adjusted according to manufacturer specifications and can be adjusted as needed.

- Unlock the adjusting screw of valve "DV1".
- Turn the valve anticlockwise= open (faster), clockwise= close (slower).
- The optimum lowering speed is reached when the dock leveller as quickly lowered as it rises.
- Secure the adjusting screw by tightening the lock nut.

This setting is the max. permitted speed from the EN 1398 with 200 mm/s respected.

### 3.4 Completing the Adjusting

It must be made a test run.

For this the operating instructions of the control unit is to be noted.

The work on the hydraulic system must be documented in a test report and attached to the log book for the dock leveller.

The following operating functions must be tested:

- Lifting,
- Swing out and swing in of the hinged lip,
- Lowering,
- Automatic return in cross traffic position, if exist
- Door release, if exist,
- Floating position,
- Leak resting of the hydraulic system,
- Oil level.

### 3.5 First Check

We recommend a first preventive check of the hydraulic system after a maximum of three months, from the time of the first commissioning of the leveler or hydraulic unit.

This check shall include:

- Check the hydraulic unit for leaks and tight fit of all fittings and connecting elements (valves, pipes, hoses, etc.),
- Check the oil level in the tank,
- Check the oil temperature,
- The oil temperature should not be over an exceed value =  $T_{amb} + 15^{\circ} C$ ,
- Check all settings on the hydraulic unit (lowering speed, lifting pressure, etc.).

If problems, defects or damage are found, they must be repaired immediately by a qualified service technician!

## Hydraulic schedule:

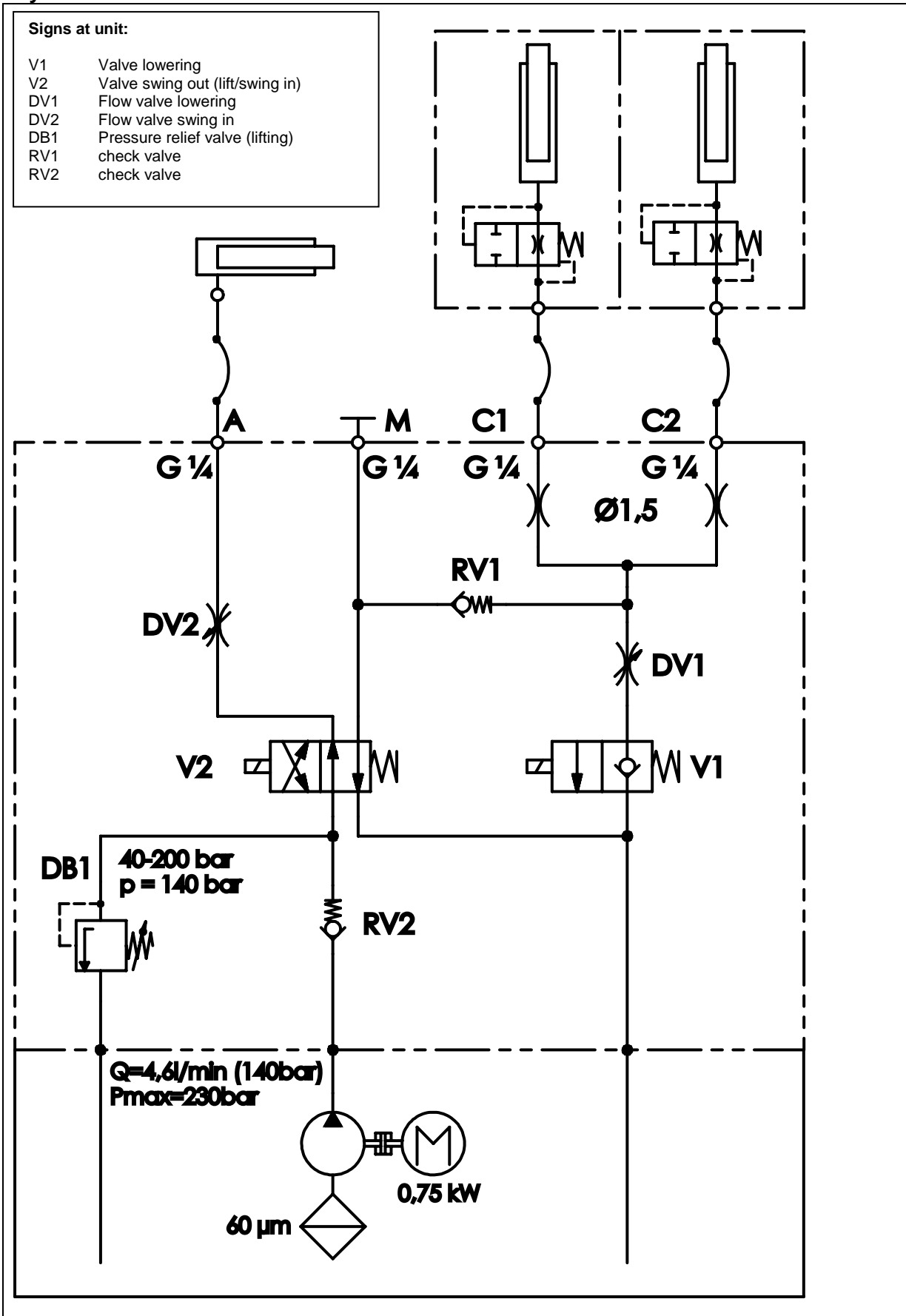

## 4 Notes

**Table 1:**

Checking and maintenance intervals to ensure safe operation of the unit

Interval	Daily	Weekly	Quarterly	Yearly	Every 2 Years
<b>Hydraulic oil</b>					
Oil level		X		X	
Temperature		X		X	
Exchange					X
<b>Hydraulic system</b>					
Leaks	X			X	
Damage			X	X	
Noisiness	X			X	

**Table 2:**

Torque for fittings and valves

Position	Component/fitting	Torque [Nm]
A	Hinged lip cylinder	30
C1/C2	Lift cylinder	30
DB1	Pressure relief valve	30+2
V1/V2	Control valve	30+2

**Table 3:**

Electrical actuation of valves

Function/valve	V1	V2
Lifting	-	X
Swing out	-	-
Lowering	X	-
Swing in	-	X



## Mounting sketch

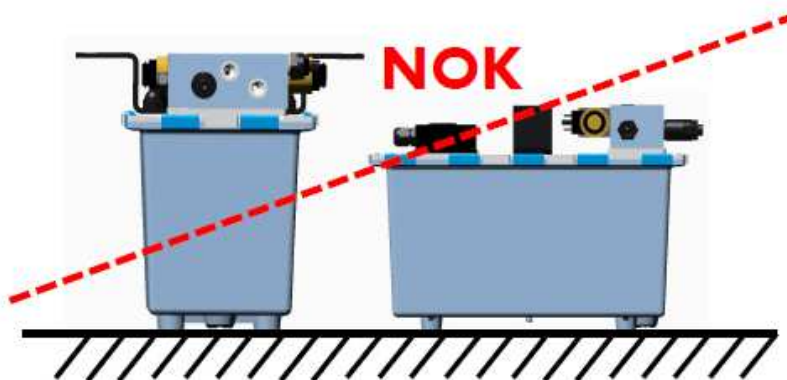
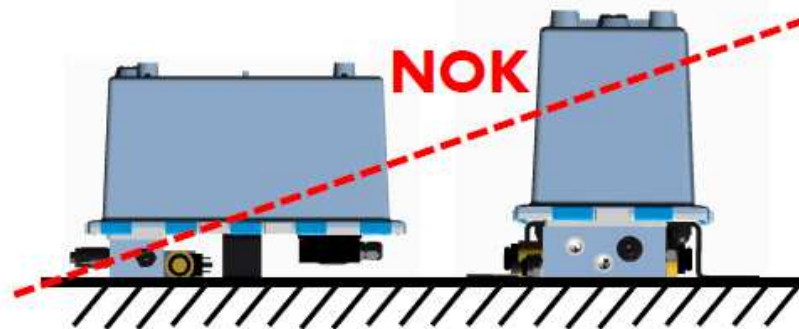
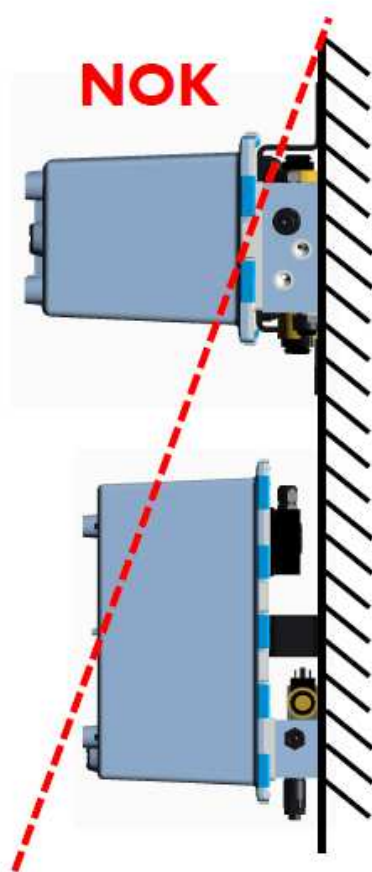
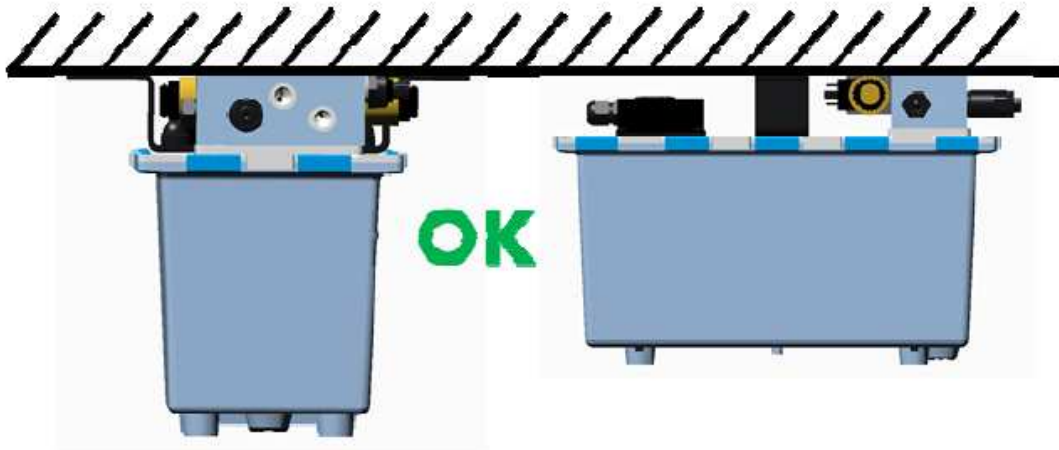

## 5 Short instruction – DS0110200

**Note:** Before this short instruction is used, the adjusting instruction must be completely read. The remarks, safety- and maintenance instructions must be observed!

### Adjusting the lift pressure

- Unlock valve “DV2” and turn clockwise to its stop (close).
- Press “Lift” button. If there is not enough pressure to lift the platform, unlock valve “DB1” and turn clockwise until the platform rises.
- Swing out the lip automatically.
- Lower platform with swing out hinged lip down to the lowest position.
- Valve “DB1” unscrew anticlockwise so far that the dock leveller no longer rises.
- Press “Lift” button and keep it pressed. Turn valve “DB1” clockwise until the dock leveller begins to lift up (floats).
- Cross the dock leveller into the upper end position, pressure measured = “floating pressure”.
- Pressure setting by turning clockwise increased to the extent that in the upper end position of the platform, a pressure equal to “floating pressure plus 15-20 bar” is measured (about 1/4 turn).
- Secure valve “DB1” by tightening the lock nut and protect by screw protection lacquer to prevent unauthorized setting.
- Finally, check the tightness of the valves. Raise the leveller platform to the upper end position and turn the main switch to “OFF”. If the platform does not sink, all valves are tight.

### Adjusting the automatic swing out movement

- Press “Lift” button.
- Turn the valve “DV2” anticlockwise and adjust so that the lip swings back within approximately 2s.
- Secure adjustment by tightening the lock nut.

### Adjusting the lowering speed of the platform

- Unlock the adjusting screw of valve “DV1”.
- Turn the valve anticlockwise= open (faster), clockwise= close (slower).
- The optimum speed is reached when the dock leveller as quickly lowered as it rises.
- Secure adjustment by tightening the lock nut.

### Completing the adjusting

- It must be made a test run.
- All operating functions are to be checked.
- The work on the hydraulic system must be documented in a test report.

